



Casanueva, Mario

Graphs and lattices as conceptual representation formats. An exploratory exercise with five specializations of Mendelian genetics



Esta obra está bajo una Licencia Creative Commons Argentina.
Atribución - No Comercial - Sin Obra Derivada 2.5
<https://creativecommons.org/licenses/by-nc-nd/2.5/ar/>

Documento descargado de RIDAA-UNQ Repositorio Institucional Digital de Acceso Abierto de la Universidad Nacional de Quilmes de la Universidad Nacional de Quilmes

Cita recomendada:

Casanueva, M. y Méndez, D. (2012). *Graphs and lattices as conceptual representation formats. An exploratory exercise with five specializations of Mendelian genetics. Metatheoria*, 3(1), 19-37. Disponible en RIDAA-UNQ Repositorio Institucional Digital de Acceso Abierto de la Universidad Nacional de Quilmes <http://ridaa.unq.edu.ar/handle/20.500.11807/2416>

Puede encontrar éste y otros documentos en: <https://ridaa.unq.edu.ar>

Graphs and Lattices as Conceptual Representation Formats. An Exploratory Exercise with Five Specializations of Mendelian Genetics*

Mario Casanueva[†]

Diego Méndez[‡]

Abstract

A graphical representation of the model-theoretic structure of explanation is used to reconstruct five distinct specializations of Mendelian genetics. Structural variations between the five models are highlighted and used to establish an inter-model variation sequence. Furthermore, the authors explore a geometrical format for the representation of thematic domains, which may reveal important tendencies of conceptual variation.

Keywords: explanation - structuralism - graphical representation - conceptual change

Resumen

Se utiliza una representación gráfica de la estructura modelo-teórica de explicación para reconstruir cinco especializaciones distintas de la genética mendeliana. Las variaciones estructurales entre los cinco modelos son resaltadas y usadas para establecer una secuencia de variación intermodélica. Más aun, los autores exploran un formato geométrico para la representación de dominios temáticos que puede revelar tendencias importantes de variación conceptual.

Palabras clave: explicación - estructuralismo - representación gráfica - variación conceptual

* Received: 12 June 2012. Accepted in revised version: 15 September 2012.

[†] Departamento de Humanidades, Universidad Autónoma Metropolitana-Cuajimalpa, México, D.F. Para contactar al autor, por favor, escriba a: mario.casanueva@gmail.com

[‡] Departamento de Humanidades, Universidad Autónoma Metropolitana-Cuajimalpa, México, D.F. Para contactar al autor, por favor, escriba a: mendezgranados@gmail.com

Metatheoria 3(1)(2012): 19-37. ISSN 1853-2322.

© Editorial de la Universidad Nacional de Tres de Febrero. Publicado en la República Argentina.

1. Introduction

The concept of model has been characterized in various ways by 20th century philosophy of science, and the relative importance of the notion, in science and philosophy of science, has also varied. People like Carnap, who considered models as nonessential to science or philosophy, albeit their heuristic and esthetic value, lost the battle. The importance of models in science has been the bedrock of a long intellectual tradition, upheld by the likes of Peirce, Maxwell, Poincaré, Campbell, Hutten, Harré, Black, Hesse, etc. As regards philosophy of science, the Semantic Conception has made the concept of “model” a fundamental tool for the analysis of scientific discourse. At present, this school of thought is gaining terrain, but it must be said that there are many variants of the Semantic Conception.

The basic idea on which the many different semantic factions agree is that a theory is a determinate family or set of models. It should be stressed that in this paper the term “model” is used in a logical-mathematical sense (due to Tarski). To offer a model for a theory is equivalent to offering an interpretation of the theory’s terms (to give them concrete meaning) so that the theory’s claims are true under that interpretation. This is a fundamentally semantic approach, opposed to the classical conception that lays emphasis on linguistic-syntactical aspects and views theories as sets of statements. As van Fraassen has stated:

According to the semantic view, to present a theory is to present a family of models. This family may be described in many ways, by means of different statements in different languages, and no linguistic formulation has any privileged status. Specifically, no importance attaches as such to axiomatization, and a theory may not even be axiomatizable in any non-trivial sense. (Van Fraassen 1989, p. 189)

The way in which models are represented varies from one particular semantic field to another. Thus, while Giere does not bestow on them any determinate mathematical form, van Fraassen sees them as topological structures of a certain phase-space. The structuralists (Sneed, Stegmüller, Moulines, Balzer and others), depict models as set-theoretic predicates, that is as structures formulated in the language of set theory.

In the present paper, models will be introduced as conceptual graphs or diagrams in the sense of category theory. Before going any further, a brief clarification regarding terminology is necessary. On occasions we use the term “model” as a graphical representation of a commutative inference system. This of course is different from the Tarskian sense, so we will indicate the Tarskian notion as “model₁” and the graphical representation as “model₂”.

Regarding the reconstruction of Mendelian theory elements, which are the objects of this paper, the authors feel that this mode of presentation has several advantages, to wit: 1) it allows one to capture the full conceptual edifice of the model, literally at a glance; 2) it allows several layers of analytical depth, insomuch that the representation can be as detailed or general as is required by context; 3) it recovers

all the main meta-scientific distinctions of the Structuralist Program, without the technical difficulty to which this school is prone. We suspect that the advantages mentioned here may be extended to other applications beyond the realm of genetics. Furthermore, having a variety of representational forms strengthens the basis of Structuralist meta-theory.

Any theoretical model postulates a set of entities and relations. If sets of these entities are represented as points, and their relations depicted as arrows, any model may be represented by a certain type of graph.

Several graphs are presented below, but first a few clarifying remarks regarding their composition are in order. Points can represent sets of simple elements, or any other structure obtained by applying set-theoretic operators. In any case, an entity may be decomposed into its simplest components (as if one were zooming in on the entity), or reorganized into a more complex structure (as if one were zooming out). As far as functions are concerned, two types of arrows are used in order to represent whether their origin and target represent the function's domain and range or elements of the domain and range.

- (i) Continuous, broken, and dotted arrows connecting points represent functions where the domain is represented by the origin point, or, if there are several points at its origin, the Cartesian product of such sets, and the function's range is the set represented by the target point. For example, an arrow going from point A to point B represents a function whose domain is A and whose range is B.
- (ii) Double-lined arrows represent functions that assign to whatever is represented by its origin point (or an n-tuple of its origin points, if more than one) whatever is represented by its target point. Here, origin and target are not the function's domain and range, but argument and value of that function under such argument. Thus, a double-lined arrow from point A to point B represents a function f such that $f(A)=B$.
 - a. Concerning double-lined arrows, we make a further distinction between those connecting a set A and an echelon set from A, and those that do not. The first ones we call "structuring".
 - b. Furthermore, double-lined arrows, besides connecting points, may also connect arrows (or arrows and points). In this case, such arrows are interpreted the same way as when connecting dots. They represent functions that take as one of its arguments the function or set at its origin, and yield whatever is represented by the point or arrow at its target.

Theory reconstruction by means of the type of diagrams we propose may give way to expedient graphical representations of larger chunks of science, such as thematic domains. While we do not dwell in depth on this point in the present paper (though we do illustrate below, with five theory elements of Mendelian genetics, the kind of visual display referred to), certain aspects of the issue should

be mentioned. Thematic domains (like the domain of biological inheritance or the domain of organic evolution) incorporate populations of similar theories (be they similar regarding structure or function), though said similarity is difficult to determine. By means of a lattice representation of a family of theories, it is possible to identify patterns of variation for the whole set, even though the theories in question do not belong to the same theory net (nonetheless, the example shown below is built with theory elements of the same theory net). An additional advantage of our approach is that it may be used to display controversies in conceptual domains (e.g. the domain of biological inheritance) as turnovers in theoretical substructures (more will be said on structural turnover below). This possibility is not entirely available with the usual notions of “holon” and “theory net”.

2. Graphical representation and explanation structure

In another paper (Casanueva & Méndez 2012), we have characterized a form of explanation, as shown in Figure 1. The arrangement is divided into two parts: one contains the problem or issue of interest, represented here by the arrow $A \rightarrow Z$. The other portion depicts the explanation offered by said model₂ ($A \rightarrow C \rightarrow D \rightarrow Z$). The fragment $A \rightarrow Z$ is given in terms which do not presuppose the model₂'s validity, that is, in non model₂-theoretic terms.¹ The other pathway is the one which introduces theoretical entities (C), operates certain inferences over C in order to obtain D, and posits interpretation rules that flow once again to the non-theoretic portion (Z). This second route represents the substructure that accounts for the problematic issue in question. Even though most models₂ function in such a manner, on occasions a single mathematical expression, M, supplies the $A \rightarrow C \rightarrow D \rightarrow Z$ trail in just one step.

The two paths are joined in a circuit, where the explanatory capacity of the model₂ lays. Moreover, they act out what the covering nomological model assigns to explicans ($A \rightarrow C \rightarrow D \rightarrow Z$) and explicandum ($A \rightarrow Z$). If for each element of A (considering that capital letters represent sets) both paths arrive at the same destiny in Z, the circuit is commutative. Other types of convergence are possible, such as inclusion, inequality, difference, approximation, etc. Whatever may be the case, inferences concerning one path can be made from the information contained in the other. Nonetheless, the model₂'s explicative strength depends on how the two routes are related. The exact same arrival point in Z confers the greatest explicative capacity, while difference confers the least. All other relations would be in some intermediate range of explanatory power. Logical and mathematical derivations from the model₂'s primitive terms may give rise to new points (additional definitions) and new arrows (derived relations), which in turn can give rise to new inferential

¹ With regard to this distinction, see Balzer, Moulines & Sneed (1987).

Figure 1

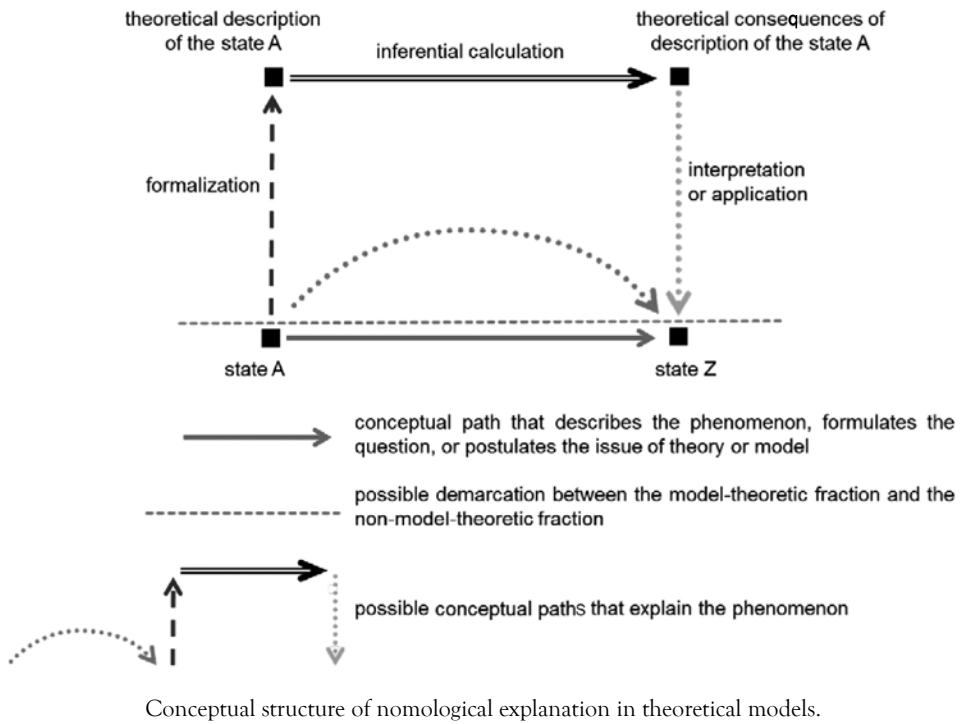

pathways (most of the double-lined arrows mentioned above are definitions or derived concepts).

3. Graphs: Mendelian genetics

Five specializations of Mendelian Genetics have been chosen in order to graphically present their conceptual structures. For the sake of simplicity, neither epistasis nor multifactorial inheritance has been included; nonetheless, the selected cases are representative of the type of conceptual variations that exist in the population of Mendelian specializations.²In these five models, constant and variable regions are identified.

Figure 2 displays one of the most well-known Mendelian scenarios: complete dominance with a 1 to 1 gene-characteristic relation (C11D). Continuous arrows frame the fundamental question of Mendelian genetics, that is: how are characteristics transmitted from generation to generation? Or phrased in other terms: why do the offspring of certain parents possess the traits they possess? These questions are captured along the path:

² A set theoretic characterization of the complete theory net appears in Casanueva (2003, chapter 4). An alternative reconstruction appears in Lorenzano (1995).

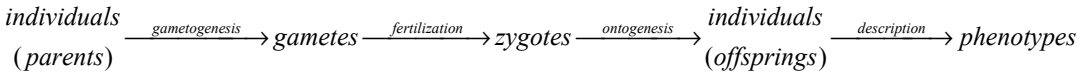

The graph is subdivided in three zones: the first constitutes what can be termed a gene space, the second a description space, and the third is the realm of uni-gamete fertilization. Each region constitutes an ontological family, the first is composed of genes or “gene families” (sets, tuples, etc.), the second includes characteristics and packages of characteristics, and the third encompasses different stages of the life cycle. In the first two zones, only structurings and identifications link the entities there contained. Biological succession laws are the binding stuff of the entities of the third sub-space. The regions outline conceptual hierarchies similar to those described by Thagard (1992).

Figure 2

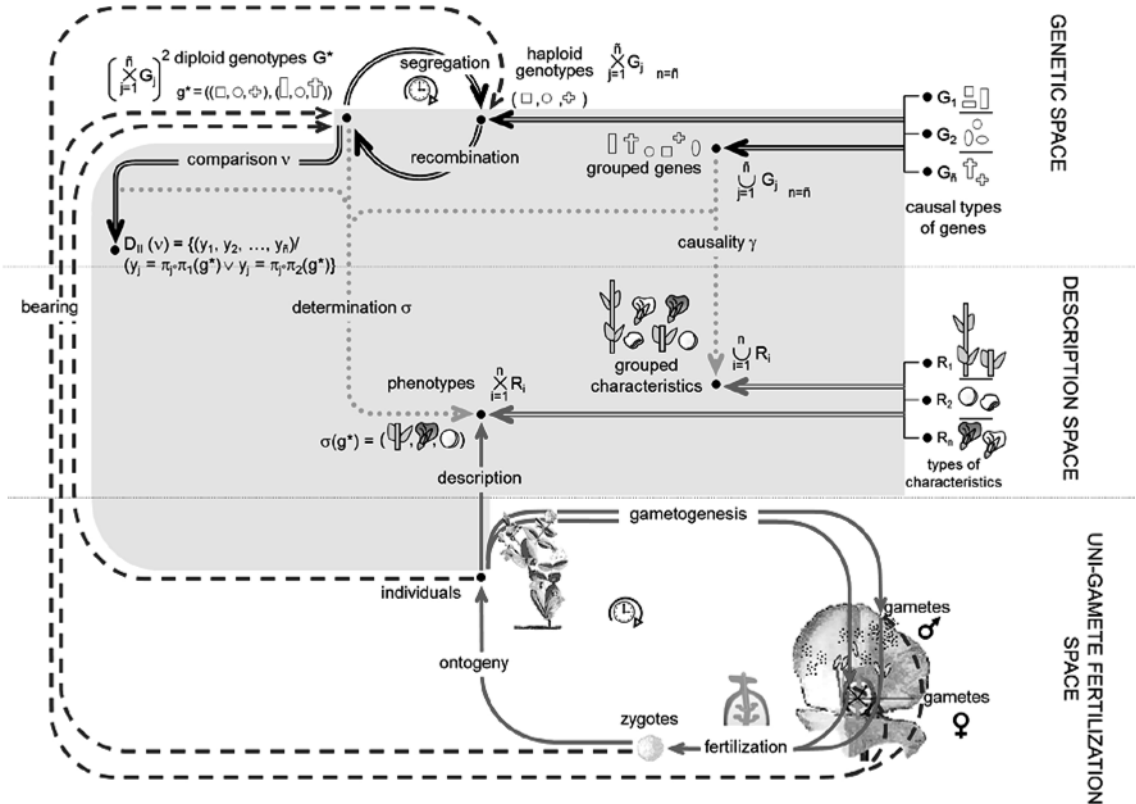

C1-1D

Mendelian model of complete dominance with 1 to 1 gene-characteristic relation (C1-1D).

The diagram shows that Mendelian genetics is a theorization over the uni-gamete theory of fertilization (UTF). Even though the concepts of “characteristic” and “phenotype” are not part of UTF, neither their use nor their determination presupposes the validity of any genetic laws. These concepts, therefore, belong in the non-theoretic portion of C11D. It should be noted that the phenotypes (macroscopic descriptions of organisms) are a structuring (double-lined arrows) of the types of characteristics. That is, a phenotype is a mosaic of traits, one of each type.

Arrows labeled “bearing” are functions that establish a nexus between life-cycle entities and model₂-theoretic entities. They indicate that individuals as well as zygotes bear diploid genotypes; gametes, on the other hand, carry haploid genotypes.

The segment of the graph which centers on the calculations C11D operates (double uppermost arrows), reveals the following items:

- (i) A structuring that injects the sets of types of genes into the union of all genes.
- (ii) How to construct or obtain haploid genotypes from the sets of alleles (genes of the same type). In a similar way as that in which phenotypes are contrived, haploid genotypes are conceived as mosaics of genes, one of each type.
- (iii) The structuring labeled “segregation”, between diploid and haploid genotypes, indicates how sets of haploid genotypes result from one particular diploid genotype. A diploid genotype is a pair of haploid genotypes, and “segregation” associates it to a set of haploid genotypes that is obtained by recombining the corresponding elements of the diploid in question. “Segregation” represents what is commonly known as Mendel’s first law or law of independent assortment.
- (iv) “Recombination” is in a sense inverse to “segregation”, since it indicates the formation of a genotype or set of genotypes from a pair of haploid genotypes (or a pair of sets of individual haploid genotypes). This structuring is known as Mendel’s second law or law of independent recombination.
- (v) The function named “comparison” (v) indicates the relative behavior of the genes that make up a diploid genotype, as far as their recessive or dominant nature is concerned. In other words, “comparison” (v) reveals which genes are expressed.

The application or interpretation phase of C11D (dotted arrows) is represented by the functions “causality” (γ) and “determination” (σ). In this case, the γ function establishes a 1 to 1 correspondence between genes and characteristics, indicating which gene causes which characteristic. In order to find the value of σ , γ and ν must be taken into account. Given a diploid genotype x , the application of ν results in a tuple of genes that are actually expressed (in this case, a sequence of \tilde{n} individual dominant genes), γ then associates each element of the series with its respective characteristic. Therefore $\sigma(x) = \langle \gamma(\pi_1(\nu(x))), \gamma(\pi_2(\nu(x))), \dots, \gamma(\pi_n(\nu(x))) \rangle$, where $\pi_i(\nu(x))$ is the i^{th} projection of $\nu(x)$.

The specializations of Mendelian genetics are variants of the above diagram, each offering a different instantiation of the highlighted area (see figures 3 to 6). But this does not mean that they are derived from the first one: all five of them are at the same level of specialization, in theory-net terms, and all of them are derived from a more general theory element (not shown) which only indicates the possibility of relation between traits and factors.

Codominance with a 1 to 1 relation (C11CD): In this specialization, the structuring that produces phenotypes changes, due to the introduction of “compound characteristics”. As an example, consider the pink flowers of *Mirabilis jalapa*. This hue should not be interpreted as the trait “pink”, but as the combination of two simple characteristics, “white flower” and “red flower”. Therefore, this flower color should be indicated by the pair (red, white).³ Each phenotype corresponds to a series of attributes, and each attribute can be either an individual characteristic or a pair of characteristics of the same type.

Due to the fact that co-dominance occurs, the causal relation between genes and characteristics (γ) includes those cases where one gene dictates the observed trait i , as well as those where the trait in question corresponds to the expression of

Figure 3

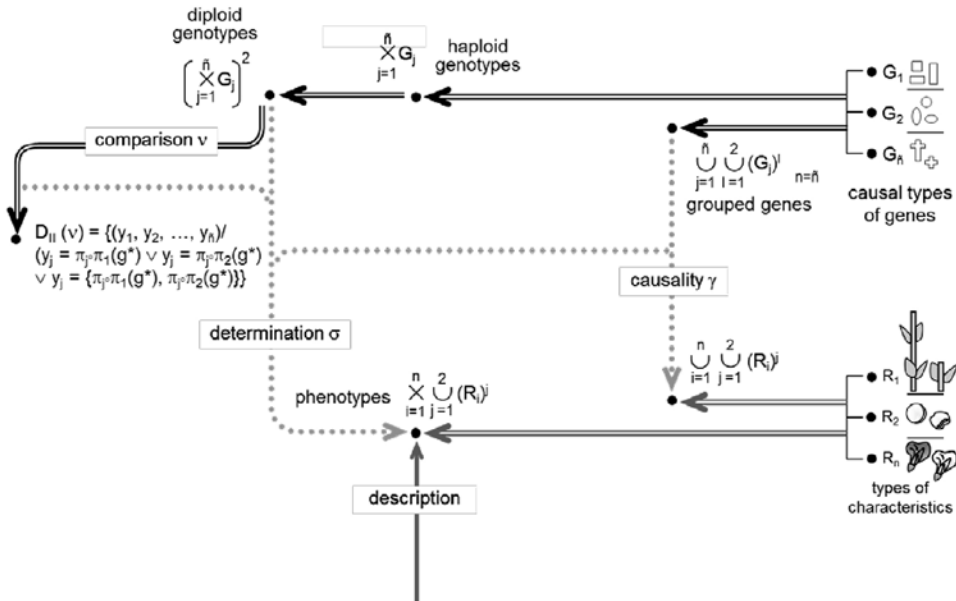

Variation unit in Mendelian models corresponding to C1-1CD.

³ It is tempting to think of “pink flower” as a distinctive trait, however, what passes for a trait in classical Mendelian models is a feature that remains constant in a pure line. This does not happen with “pink flower”, but does occur with “white flower” and “red flower”. Therefore, “pink flower” is not an element of the set of simple traits. It should be noted that “trait” is not a Mendelian genetic-theoretical term, what is Mendelian genetic-theoretical is the relationship between traits and factors.

a pair of genes. This accounts for the make-up of the domain of γ in C11CD. As far as the co-domain is concerned, the observed trait may be a pair of analogous Mendelian characteristics. Therefore, the pair (light gene, dark gene) corresponds with the pair (light flower, dark flower). Since ν yields the genes that are actually expressed, the co-domain of ν includes pairs of genes, for similar reasons that such pairs are also elements of the domain of γ .

Gene interaction with complete dominance (CVIID): This is a non-epistatic interaction, in that the phenotypic expression of the different pairs of genes is not affected by the alleles of other pairs. What characterizes CVIID is that the first generation hybrids do not resemble either parent, and those of the second generation seem to possess new characteristics, which are really the result of gene interactions in new combinations of genes. This model introduces a new function, α , which identifies the sets of genes that determine trait types.

The domain of α is the set of gene classes, and its co-domain is an initial section of the natural numbers. A very simple association rule is applied: each type (or class) of gene is assigned the subscript of the characteristic type these genes help determine. For this reason, the number of characteristic types is strictly less than the number of gene classes (since at least one trait is caused by two or more pairs of alleles).

The domain of γ is a set of gene tuples, and the lengths of these tuples vary according to the number of alleles that cause the same characteristic. In other words, either one gene or a set of genes may cause a particular trait.

The association rule operated by the σ function is as follows. Given a certain diploid genotype, the genes that are actually expressed are derived by applying the function ν (ν 's co-domain is the same as in the case of C11D). On the other hand, given the structure of γ 's domain, one must find a sequence of genes that causes a certain characteristic, say C_i . This is done by identifying, via α , which genes obtained from ν determine this characteristic (the subscript i of C_i). Next, an ordering of these genes is necessary so that when γ is applied to the resulting tuple, C_i is produced.

Epistatic interactions are not dealt with in this paper; however, a few words about them seem in order. Occasionally, when two or more non-allelic genes determine the same characteristic, one gene or combination of genes masks the effect of another gene or of another gene combination. This phenomenon is known as epistasis. When it occurs, phenotype frequencies of the second hybrid generation deviate from those of the classical Mendelian scenario (3:1, 9:3:3:1). The graphic representation of an epistatic model would require imposing restrictions on γ 's domain and codomain, in order to highlight the types of behavior epistatic genes have in regard to other alleles.

Figure 4

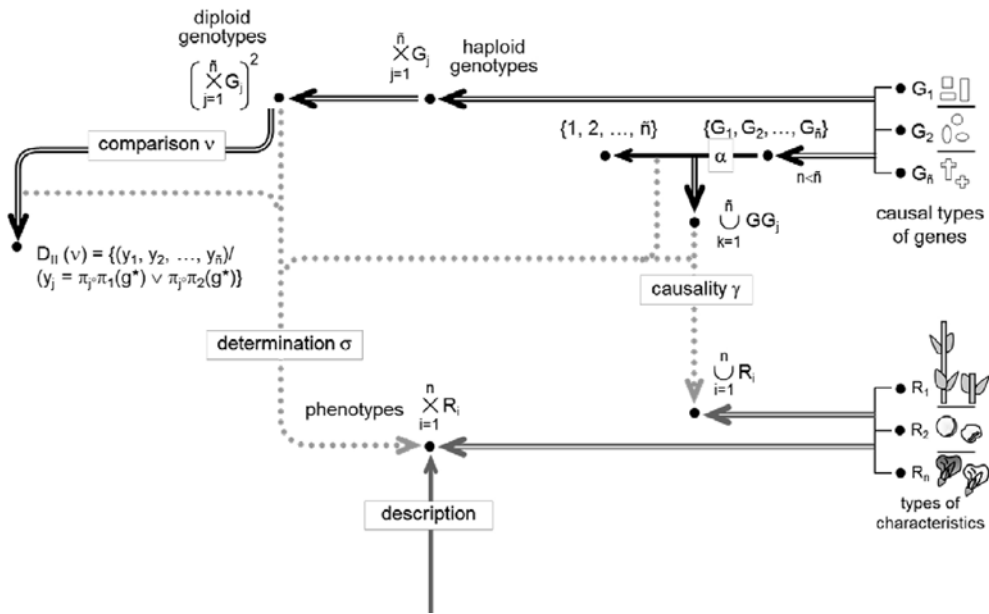

Variation unit in Mendelian models corresponding to CV-IID.

Pleiotropy with complete dominance (CPD): As has been said before, some characteristics depend on the interaction of several pairs of genes. In fact, this is probably a very common occurrence, perhaps even a norm. Nonetheless, it is also true that many pairs of genes determine several characteristics. This is the case of CPD. Here the phenotypes correspond to sequences of tuples of characteristics. One pair of genes causes each tuple.

The domain of γ is the set of all genes (in the same way as in C11D), but the co-domain is structured in a manner that is analogous to the function's domain in CVI1D. In order to construct γ 's domain, one must introduce a function β , which regroups the characteristics that result from the action of one gene. β has the set of characteristic types as domain, and an initial section of the natural numbers as range. The association rule is quite straightforward: each characteristic type is associated to the subscript of the gene class, the members of which cause the traits confined in the type. For this reason, the number of gene classes is strictly less than the number of characteristic types (since at least one pair of genes causes two or more characteristics).

γ 's co-domain is a set of characteristic tuples, such that the elements of each member belong to different types, and the length of each tuple varies according to the number of characteristics caused by the same gene. If a given vector x is a member of γ 's co-domain, then all tuples of the same form (that is, all those that

contain the same characteristic types and same number of them as x does) are also included in said co-domain.

The rule established by σ is as follows. Given a certain diploid genotype, the genes that are actually expressed are derived by applying the function v (v 's co-domain is the same as in the case of C11D). The genes so identified are then associated to sequences of characteristics, as stipulated by the function γ .

Figure 5

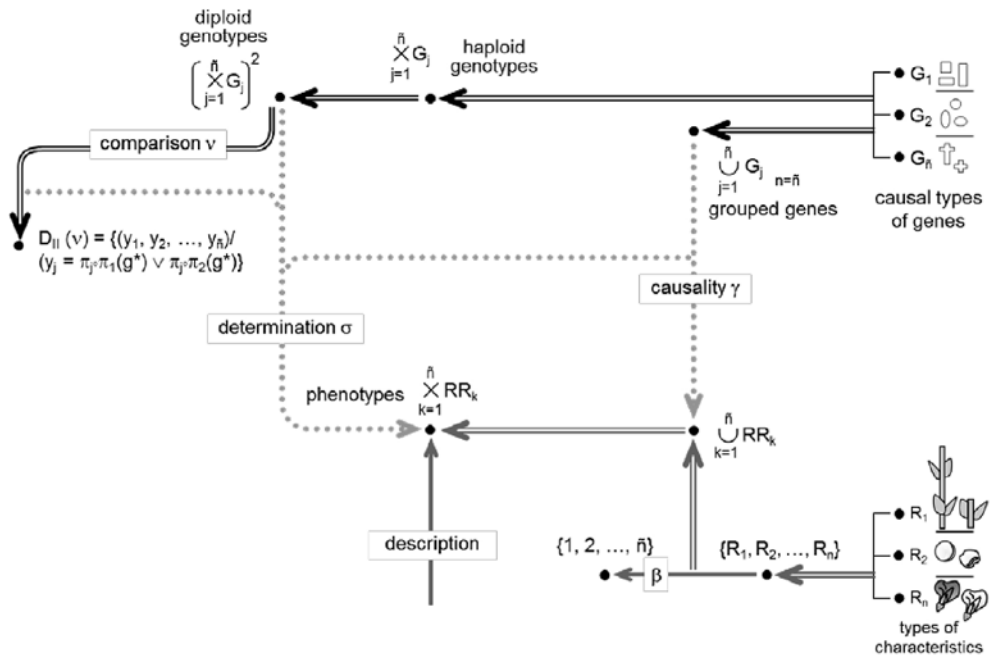

Variation unit in Mendelian models corresponding to CPD.

Pleiotropy with co-dominance (CPCD): In this case, phenotypes are sequences, the elements of which may be either a series of characters or a pair of character series. The differences with CPD are due to the issue of co-dominance. It is this consideration that underlies the make-up of the domain and co-domain of γ . As is to be expected, the domain of v is the same as in C11CD. σ 's association rule is also the same as in C11CD.

Figure 6

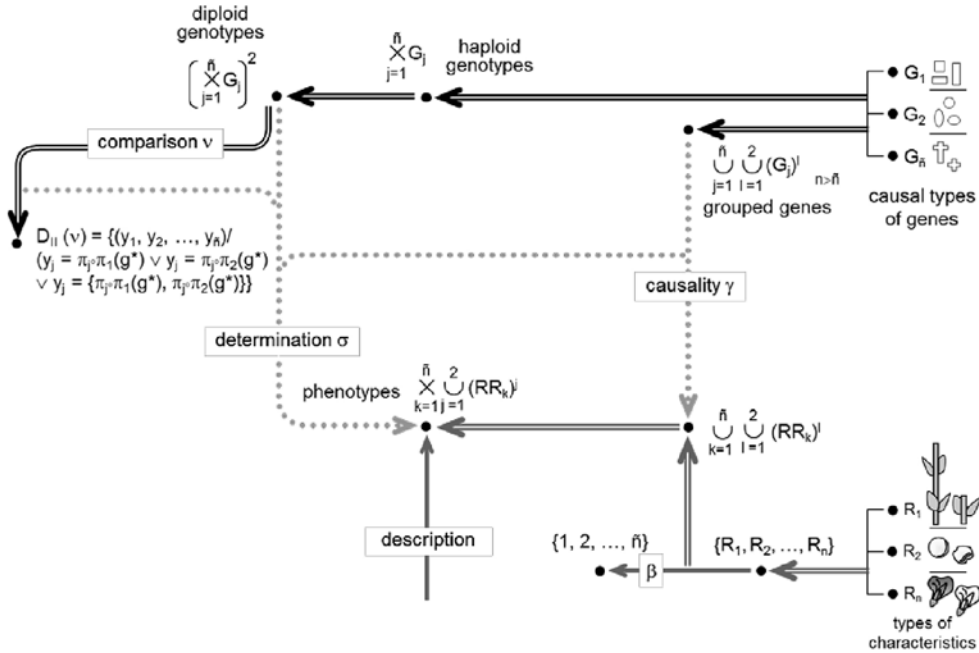

Variation unit in Mendelian models corresponding to CPCD.

4. Substructures and ordination of thematic domains

Graphs are structures composed of distinct parts. The importance of this rather obvious statement is that certain parts may be regarded as units of variation in a population of models₂. Besides points and arrows, within a graph one can distinguish compound substructures, sub-graphs, or “cut-outs” that include more than one individual element. For example, the uni-gamete fertilization theory that constitutes the base of the five genetic specializations mentioned before can be seen as a “cut-out” or sub-graph. The elements that make up a substructure must be contiguous, that is linked in a continuous or connected manner. A graph may be visualized, then, as a mosaic of sub-structures, $\langle SE_1, SE_2, \dots, SE_n \rangle$, if these are selected adequately. Figure 7 (a to d) displays a collection of 20 different “cut-outs” obtained from the five Mendelian models described above.

Figure 7a

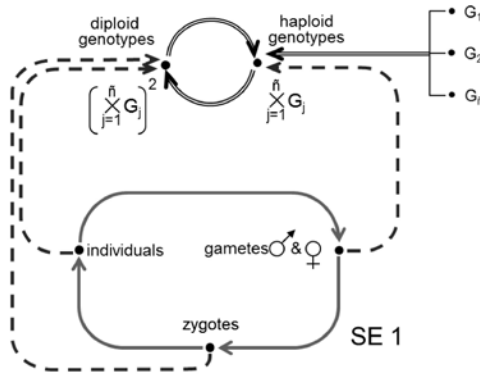

Variation unit present in all models. The part corresponding to gametogenesis and fertilization has been simplified; this does not affect our analysis since the substructure in question is common to all models.

Figure 7b

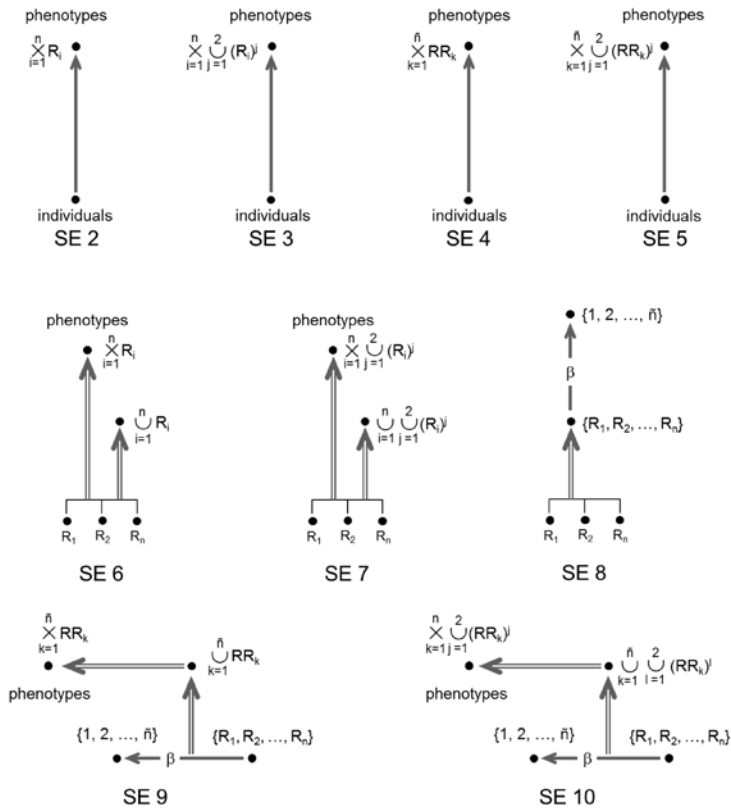

Variation units present in the “inferential calculus” portions (T-theoretical) of the different specializations.

Figure 7c

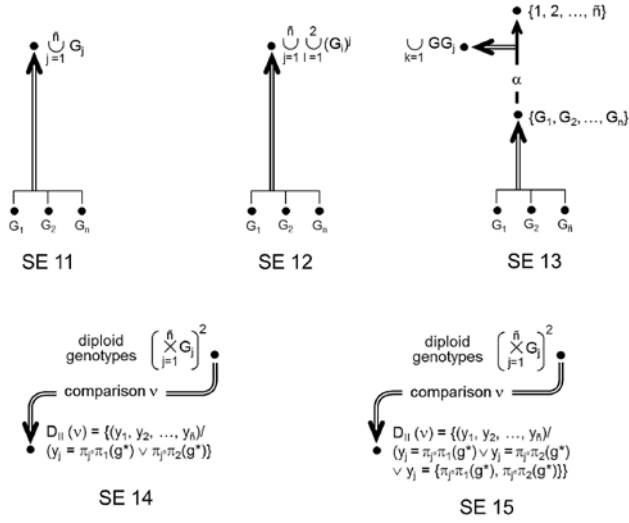

Variation units present in the non T-theoretical portions of the five Mendelian specializations.

Figure 7d

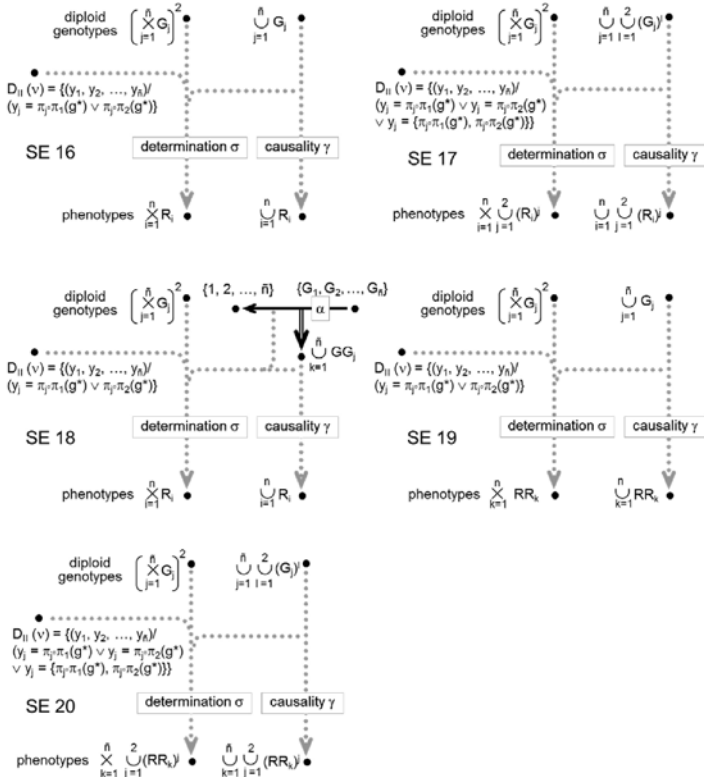

Variation units present in the “interpretation or application” portions (nomological issue, laws of models) of the different specializations.

A thematic domain is the conceptual space that contains the diverse theoretic alternatives to a basal problem. This is the problem that all the models₂ of the domain propose to solve. Genetic theories, be they Mendelian or non-Mendelian, propose a solution to the trans-generational transmission of characteristics. It is this common objective that allows the theories in question to debate and dialogue with each other. However, the models₂ do not necessarily characterize the basal problem in the same manner, nor do they have to give equal weight to the same features of said problem.

The thematic domain can be visualized as a place of confluence, where different models (both models₁ and models₂) “discuss” a particular theme or topic. It is the place where they exert mutual influences and tensions on each other, resulting in their own modification. These transformations are particularly evident when one model₂ incorporates structures of another,⁴ or partially imitates structures of another.⁵

Table 1

	C11D	C11CD	CV11D	CPD	CPCD
SE1	1	1	1	1	1
SE2	1	0	1	0	0
SE3	0	1	0	0	0
SE4	0	0	0	1	0
SE5	0	0	0	0	1
SE6	1	0	1	0	0
SE7	0	1	0	0	0
SE8	0	0	0	1	1
SE9	0	0	0	1	0
SE10	0	0	0	0	1
SE11	1	0	0	1	0
SE12	0	1	0	0	1
SE13	0	0	1	0	0
SE14	1	0	1	1	0
SE15	0	1	0	0	1
SE16	1	0	0	0	0
SE17	0	1	0	0	0
SE18	0	0	1	0	0
SE19	0	0	0	1	0
SE20	0	0	0	0	1

Within the Semantic Conception, the Structuralist Program offers graphic representations of theory nets and theory holons which are, in effect, renderings of certain types of conceptual spaces. However, such portrayals are based on intertheoretical

⁴ Consider, for example, the incorporation of the biometricians’ correlation table in the Mendelians’ theoretical and instrumental paraphernalia (see Fisher 1918).

⁵ For example, Yule’s (1902) attempt to derive the law of ancestral inheritance from quasi-Mendelian models.

relations; other “slices of science”, modes of display, and other characterizations of conceptual space, are possible. We explore these issues in the following paragraphs.

As an abstract space, the domain can incorporate the effects that scientific debate has on the models involved (both models₁ and models₂). A domain induces a spatial representation of its objects (scientific theories) in such a way that inter-model₂ similarity relations are revealed. In various fields of study, investigations that require the construction of a “concept space” usually do this by means of a multivariate algorithm, such as multidimensional scaling, correspondence analysis or some other procedure. The same strategy may be applied in building a theoretical thematic domain, but issues regarding the choice of algorithm as well as the choice of inter-model distance or similarity formula arise, for which there is no satisfactory or clear-cut answer. The technique known as Formal Concept Analysis (Davey & Priestly 2002, Widdows 2004, Willie 2005) seems to be a more viable alternative, since it operates on purely set-theoretic principles, without having to ponder dubious numerical inter-model proximity indices. The domain is represented as a lattice that highlights structural variation among the theories in question. In what follows, Formal Concept Analysis will be used to create a domain space with the five Mendelian models mentioned above.

Figure 8

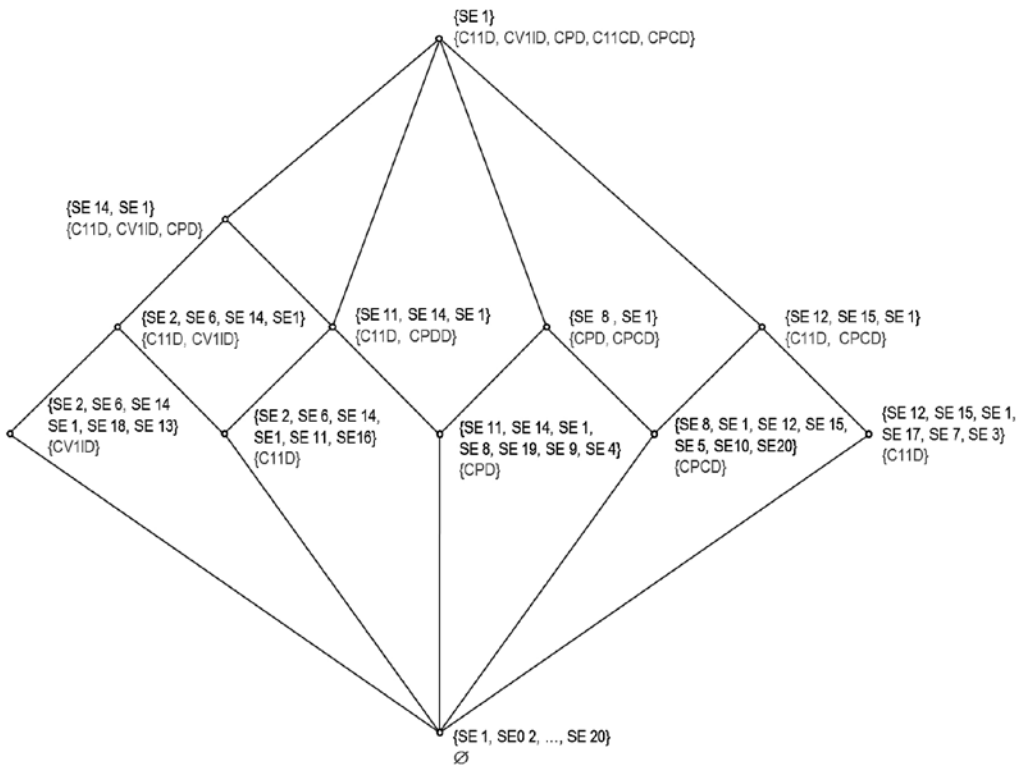

Mendelian Concept Lattice.

The arrangement of Mendelian models versus substructures (Table 1) may be recast as a tuple $K = \langle M, S, I \rangle$, such that M is the set $\{C11D, C11CD, CV11D, CPD, CPCD\}$, S is $\{SE_1, SE_2, \dots, SE_{20}\}$, and I is a subset of $M \times S$. This last relation states that for every $\langle x, y \rangle \in I$, y is a substructure of x . Given any subset A of M , a set B may be defined so that $B \equiv \{s \in S / \langle m, s \rangle \in I \text{ for all } m \in A\}$. Likewise, for any subset B of S , one can define a set $A \equiv \{m \in M / \langle m, s \rangle \in I \text{ for all } s \in B\}$. Consider now two pairs of sets (A_1, B_1) and (A_2, B_2) , where $B_i \equiv \{s \in S / \langle m, s \rangle \in I \text{ for all } m \in A_i\}$; it is possible to stipulate an order relation, \leq , so that $(A_1, B_1) \leq (A_2, B_2)$ if and only if $A_1 \subseteq A_2$, which further implies that $B_2 \subseteq B_1$. With these criteria, table 1 can be converted into a concept lattice, like the one depicted in figure 8.

Each point of the lattice represents a pair of sets, and each connecting line reveals the order relation just mentioned. The five central nodes represent, each, a single Mendelian model with all its substructures (substructures that are found only in that model). Nodes closer to the apex of the lattice also represent Mendelian concepts, but of a more diffuse kind. Take the node marked by the set $\{C11D, CV11D, CPD\}$, for example; it represents the class of models in which gene dominance is prevalent (S_{14} is the substructure pertaining to dominance).

There is a peculiar emerging pattern in figure 8: the five central points of the lattice outline the sequence $CV11D, C11D, CPD, CPCD$, and $C11CD$. Of course, none of these points are interconnected directly, since such an edge would not comply with the order relation \leq (in other words, no single Mendelian model is a join or a meet of another single Mendelian model). Nonetheless, \leq induces a clear pattern, with no confusing crisscrosses, from which the sequence in question arises. It is tempting to view the series $CV11D, C11D, CPD, CPCD, C11CD$ as a trajectory of structural variation. In fact, the lattice in figure 8 reveals how substructures are alternating along the series; figure 9 just accentuates this aspect of the preceding diagram. The sequence $CV11D, C11D, CPD, CPCD, C11CD$ combines variability of gen-characteristic interaction, variability of the phenotype concept, and variability of the gen-dominance relation.

Figure 9

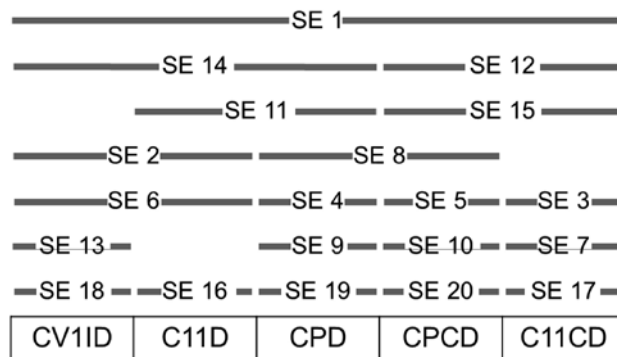

Substructure distribution along a Mendelian model sequence.

Theory specialization can be represented as a branching tree, like the Structuralist Program proposes: the base node being the least restricted variant of the theory in question (its fundamental law is not hampered by special laws), while branch nodes reveal the more constrained versions of said theory (the fundamental law's scope is limited by special laws). Mendelian genetics fits a tree-like structure very well (see Casanueva 2003), and it would seem that any other ordering instrument, such as Formal Concept Analysis, is uncalled for.

Nonetheless, a lattice display could be viewed as an alternative mode of presenting specialization orders, instead of structuralism's tree-like theory nets, since the lattice arranges the models₂ by means of a sequenced compounding of restrictions (specializations). Further study is necessary regarding the comparison of these two modes of presentation, though they seem very similar. Notwithstanding, the lattice (unlike the theory net) does not presuppose an essential element that must be present in any type of model₂ (the fundamental law); emphasis is placed on the units of structural variation. In a future paper we will discuss in depth the differences between these two arrangements.

Still, a thematic domain covers more than single theory evolution or specialization net. Several different and competing theories, each with a host of variants, can make up a domain. Formal Concept Analysis may prove to be a powerful tool in representing such a complex structure.

References

- Balzer, W., Moulines, C.U. and J.D. Sneed (1987), *An Architectonic for Science. The Structuralist Program*, Dordrecht: Reidel.
- Casanueva, M. (2003), *Mendeliana*, México: Universidad Autónoma Metropolitana (Unidad Iztapalapa)/Miguel Ángel Porrúa.
- Casanueva, M. and D. Méndez (2012), “Grafos representacionales y dinámica de teorías”, in Peris-Viñé, L.M. (ed.), *Filosofía de la Ciencia en Iberoamérica: Metateoría estructural*, Madrid: Tecnos, pp. 485-505.
- Davey, B.A. and H.A. Priestly (2002), *Introduction to Lattices and Order*, Cambridge: Cambridge University Press.
- Fisher, R.A. (1918), “The Correlation between Relatives on the Supposition of Mendelian Inheritance”, *Transactions of the Royal Society of Edinburgh* 52: 399-433.
- Giere, R.N. (1990), *Explaining Science: A Cognitive Approach*, Chicago: The University of Chicago Press.
- Lorenzano, P. (1995), *Geschichte und Struktur der klassischen Genetik*, Berlin: Peter Lang.
- Thagard, P. (1992), *Conceptual Revolutions*, New Jersey: Princeton University Press.
- Van Fraassen, B.C. (1989), *Laws and Symmetry*, Oxford: Clarendon Press.
- Widdows, D. (2004), *Geometry and Meaning*, Stanford: CSLI.
- Wille, R. (2005), “Formal Concept Analysis as Mathematical Theory of Concepts and Concept Hierarchies”, in Ganter, B., Stumme, G. and R. Wille (eds.), *Formal Concept Analysis: Foundations and Applications*, Berlin: Springer-Verlag, pp. 1-33.
- Yule, G.U. (1902), “Mendel’s Laws and Their Probable Relations to Intra-Racial Heredity”, *New Phytologist* 1: 193-200, 222-238.